

YOUR WARRANTY.

REGARDLESS OF CAUSE, IF A PRODUCT YOU BUY FROM AEROTECH DOES NOT WORK RIGHT, AEROTECH WILL REPAIR OR REPLACE IT ONCE, AT NO CHARGE, FOR UP TO ONE YEAR FROM THE DATE OF DESPATCH FROM THE FACTORY.

IN THE COURSE OF REPAIR OR REPLACEMENT, AEROTECH MAY SEND YOU WRITTEN RECOMMENDATIONS ON HOW TO PREVENT A PROBLEM FROM HAPPENING AGAIN. AEROTECH RESERVES THE RIGHT TO WITHDRAW THIS WARRANTY IF YOU DO NOT FOLLOW THESE RECOMMENDATIONS. CUSTOMER IS RESPONSIBLE FOR P&F AND FREIGHT CHARGES BOTH TO AND FROM AEROTECH IN ALL CASES.

THIS WARRANTY DOES NOT APPLY TO ELECTRIC MOTORS, ELECTRICAL CONTROLS IF ANY, WHICH AEROTECH OBTAINS FROM OTHER MANUFACTURERS. A MOTOR CARRIES ONLY THE WARRANTY OF THE COMPANY THAT MAKES IT.

THIS WARRANTY IS EXCLUSIVE AND IS IN LIEU OF ALL OTHER WARRANTIES, WHETHER WRITTEN, ORAL OR IMPLIED, INCLUDING THE WARRANTY OF MERCHANTABILITY AND OF FITNESS FOR ANY PARTICULAR PURPOSE AEROTECH'S LIABILITY IS IN ALL CASES LIMITED TO THE REPLACEMENT PRICE OF ITS PRODUCT. AEROTECH SHALL NOT BE LIABLE FOR ANY OTHER DAMAGES, WHETHER CONSEQUENTIAL, INDIRECT, OR INCIDENTAL, ARISING FROM THE SALE OR USE OF ITS PRODUCTS.

AEROTECH MAY MODIFY THIS WARRANTY, BUT ONLY BY SIGNING A SPECIFIC, WRITTEN DESCRIPTION OF ANY MODIFICATIONS.

WE, AEROTECH GROUP OF COMPANIES GIVE ABSOLUTELY NO WARRANTY ON ANY BOUGHT OUT ELECTRICAL ITEMS SUCH AS ELECTRIC MOTOR ETC, AND ALONG WITH THIS, IF YOUR SELECTED AND CONFIRMED AEROTECH PRODUCT IS NOT USED PROPERLY BY BUYER, CUSTOMER AND OR END USER WHICH INCLUDES PIPE CONNECTIONS, JOINTINGS, FITTINGS AS WELL AS POWER SUPPLY, LOAD, OVER LOAD AND FAILOUR OF MOTOR AND OVER HEATING OF EITHER MOTOR AND OR AEROTECH PRODUCT PARTS AND ANY DAMAGES OBSERVED ARE NOT COVERED UNDER WARRANTY.

ANY DAMAGES, CHANGES IN AND ON PARTS SUPPLIED BY US SUCH AS FRP SILENCERS AND ELECTRIC MOTOR COOLING FAN OBSERVED THAT PRODUCT IS NOT UTILISED IN PROPER WAY AND MISUES OF AEROTECH PRODUCT CONCLUDES WITHDRAWL OF OFFERED WARRANTY FROM THAT PERIOD.

YOUR WARRANTY.

REGARDLESS OF CAUSE, IF A PRODUCT YOU BUY FROM AEROTECH DOES NOT WORK RIGHT, AEROTECH WILL REPAIR OR REPLACE IT ONCE, AT NO CHARGE, FOR UP TO ONE YEAR FROM THE DATE OF DESPATCH FROM THE FACTORY.

IN THE COURSE OF REPAIR OR REPLACEMENT, AEROTECH MAY SEND YOU WRITTEN RECOMMENDATIONS ON HOW TO PREVENT A PROBLEM FROM HAPPENING AGAIN. AEROTECH RESERVES THE RIGHT TO WITHDRAW THIS WARRANTY IF YOU DO NOT FOLLOW THESE RECOMMENDATIONS. CUSTOMER IS RESPONSIBLE FOR P&F AND FREIGHT CHARGES BOTH TO AND FROM AEROTECH IN ALL CASES.

THIS WARRANTY DOES NOT APPLY TO ELECTRIC MOTORS, ELECTRICAL CONTROLS IF ANY, WHICH AEROTECH OBTAINS FROM OTHER MANUFACTURERS. A MOTOR CARRIES ONLY THE WARRANTY OF THE COMPANY THAT MAKES IT.

THIS WARRANTY IS EXCLUSIVE AND IS IN LIEU OF ALL OTHER WARRANTIES, WHETHER WRITTEN, ORAL OR IMPLIED, INCLUDING THE WARRANTY OF MERCHANTABILITY AND OF FITNESS FOR ANY PARTICULAR PURPOSE AEROTECH'S LIABILITY IS IN ALL CASES LIMITED TO THE REPLACEMENT PRICE OF ITS PRODUCT. AEROTECH SHALL NOT BE LIABLE FOR ANY OTHER DAMAGES, WHETHER CONSEQUENTIAL, INDIRECT, OR INCIDENTAL, ARISING FROM THE SALE OR USE OF ITS PRODUCTS.

AEROTECH MAY MODIFY THIS WARRANTY, BUT ONLY BY SIGNING A SPECIFIC, WRITTEN DESCRIPTION OF ANY MODIFICATIONS.

WE, AEROTECH GROUP OF COMPANIES GIVE ABSOLUTELY NO WARRANTY ON ANY BOUGHT OUT ELECTRICAL ITEMS SUCH AS ELECTRIC MOTOR ETC, AND ALONG WITH THIS, IF YOUR SELECTED AND CONFIRMED AEROTECH PRODUCT IS NOT USED PROPERLY BY BUYER, CUSTOMER AND OR END USER WHICH INCLUDES PIPE CONNECTIONS, JOINTINGS, FITTINGS AS WELL AS POWER SUPPLY, LOAD, OVER LOAD AND FAILURE OF MOTOR AND OVER HEATING OF EITHER MOTOR AND OR AEROTECH PRODUCT PARTS AND ANY DAMAGES OBSERVED ARE NOT COVERED UNDER WARRANTY.

ANY DAMAGES, CHANGES IN AND ON PARTS SUPPLIED BY US SUCH AS FRP SILENCERS AND ELECTRIC MOTOR COOLING FAN OBSERVED THAT PRODUCT IS NOT UTILISED IN PROPER WAY AND MISUSE OF AEROTECH PRODUCT CONCLUDES WITHDRAWAL OF OFFERED WARRANTY FROM THAT PERIOD.

AEROTECH ENGINEERING COMPANY
39, TIRUPATI INDUSTRIAL ESTATE,

AEROTECH

BLOWER ARRANGEMENT:

Mainly consists of a dynamically balanced impeller located centrally in the bottom housing with very fine diametrical and face clearances. Impellers are directly mounted on the motor drive shaft. Both suction and pressure openings are located on the outer periphery of the Top and Bottom housing.

PRINCIPAL OF OPERATION:

In the chambers set in the periphery of the impeller, air is accelerated due to centrifugal force created as the impeller turns, and is thrown into the side channels. It then flows into the next chamber, and is again similarly accelerated, thus continuously increasing compression as the impeller turns until it reaches the outlet port.

The impeller rotates without contact with the inside of the housing, the compression space is free from oil and wear.

INSTALLATION AND OPERATION:

- The blowers are supplied as a complete unit mounted with vertical flange mounted motor. Whilst installation it is recommended that the unit be properly bolted or fixed through foundation holes provided on the bottom housing of the blower.
- Connect the suction and pressure openings to your equipment or system by means of rigid or flexible piping or non-collapsible flexible pipe of suitable diameter.
- **Electric supply to motor should be given through Star Delta connection with proper earthing and single phase preventor. Over load relay in the Star Delta should be set as per the rating of the motor or 0.5 to 1.0 amps more than current drawn during application according to rating of the motor. Direction of rotation should be as per the arrow marked on the motor or anticlockwise from top of motor.**
- **Direction of rotation should be as per the arrow marked on the motor or anticlockwise.**
- Ensure that the impeller rotates freely without any frictional noise.
- **These blowers are meant for handling clean and dry air only.**
- Recommended to provide vapor / liquid traps and **suction filters between blower and your system.**
- The blowers are designed for continuous rating but precautions to be taken during installation for better heat dissipation

MAINTENANCE AND PRECAUTIONS:

These blowers require little day to day maintenance, since no lubrication is required. If suitable suction filter has been incorporated in the system, the blowers will give trouble free performance even when continuously used. **After prolonged use suction filter may be cleaned occasionally.**CHECK:

Free rotation of the impeller when put off. Suction filters are cleaned periodically. Suction or exhaust pipe lines for clogging with dust.

OVERHAULING:

When the blower is to be dismantled for breakdowns or maintenance, procedure to be followed

- Switch off the power supply of the blower motor.
- Disconnect the blower from the system.
- Remove the silencers.
- Dismantle the blower by unscrewing the assembly bolts. The blower separates in to 1. Bottom housing and 2. Motor with Impeller and Top housing.
- Keep the blower up side down and detach the impeller by unscrewing the locking bolt.
- Remove the burrs if any and clean the parts.

REASSEMBLY:

- Mount the impeller on the motor shaft, tighten the locking bolt with locking washer.
- Rotate the impeller by hand for free rotation.
- Fit the bottom housing on top housing and again ensure free rotation.
- Mount the silencers and take the running trial.
- **Do not hammer or machine any part of the blower.**

TROUBLE SHOOTING & TEST AND REMEDY:

- **MOTOR OVER LOAD:** Check freeness of the blower without dismantling the motor. Run the motor alone after dismantling and check the current, voltage and connections.
- **ABNORMAL SOUND:** Check for free rotation of the blower. Dismantle the blower and check for any foreign particles inside the blower. Check the motor bearings.
- **JAMMED:** Dismantle the blower and check the shaft for resistance to rotation, bearing worn out, check for any frictional burrs / foreign particles.

Please read **Warranty** terms carefully **AEROTECH ENGINEERING COMPANY**

Connection Diagram

For 1/2800 to 3/2800 Induction Motor

STAR CONN.

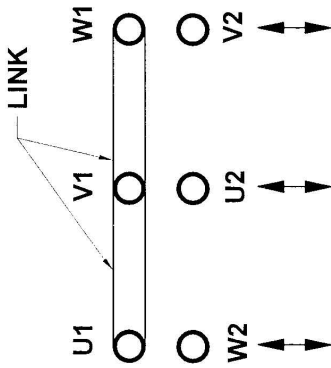

Supply 415v (3Ø)

DELTA CONN.

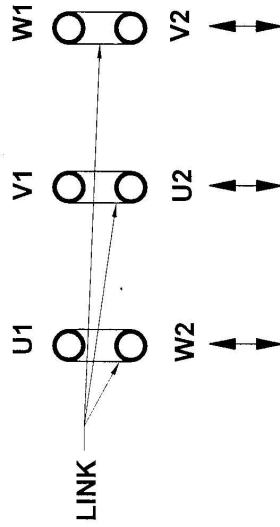

Supply 230v (3Ø)

Connection Diagram

For 5/2800 & Above Induction Motor

Star Delta Starter

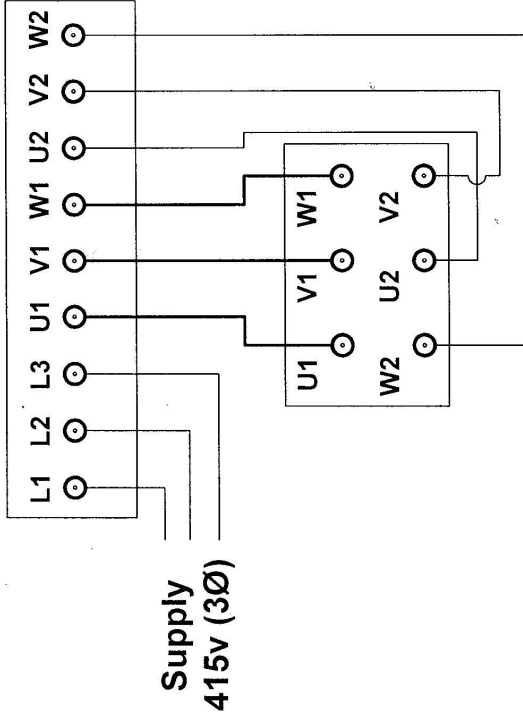

Supply
415v (3Ø)

Motor Terminal

D.O.L Starter

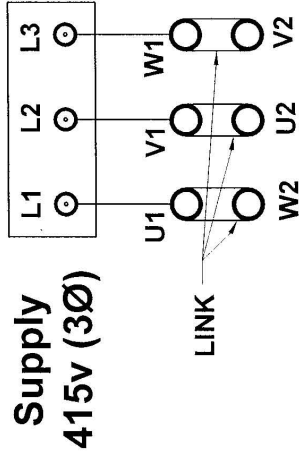

Supply
415v (3Ø)

LINK

Motor Terminal